

**THE VILLAGE OF COPENHAGEN BOARD OF TRUSTEES
BOARD PACKET
AT THE VILLAGE HALL
SEPTEMBER 10, 2025
18:30:00/6:30 PM**

**PLEDGE OF ALLEGIANCE
APPROVAL OF AUGUST MINUTES**

**UPDATES
RACOG**

THE VILLAGE OF COPENHAGEN BOARD OF TRUSTEES
BOARD PACKET
OCTOBER 8, 2025

RIVER AREA COUNCIL OF GOVERNMENTS

September 2025

MUNICIPAL MANAGEMENT MONTHLY ANNOUNCEMENTS



RACOG UPDATES

- **RACOG Economic Visioning Summit**

Is scheduled for March 19, 2026 at the Howard G. Sackett Technical Center.

- **Student Activity & Outreach**

RACOG Student Board - We will be trying to reconvene the board in September.

Civic Service Student Activity Program (CSSAP) - Will be meeting with guidance counselors this month.

- **Water/Wastewater**

Wastewater Operator Training - This will be moving forward. They are looking for communities who might be willing to host interns, so they can get their work hours needed to become certified wastewater operators.

- **RACOG Associate Circuit Riders**

We have all three associates available to cover meetings right now. One will be acting as an emergency backup primarily.

- **Naturally Lewis Funding Opportunity**

We will have a proposal ready for RACOG to look at, at the next board meeting.

- **RACOG Website**

Working on ADA accessibility and will be looking to move RACOG over to a .gov site.



UPCOMING

Next RACOG Meeting

September 25, 2025 @ 6:00 PM

Town of Wilna Municipal Building

Ryan Piche, Jefferson County

Administrator & Tim Hunt, Lewis County
Manager

Commission Annual Dinner

October 9, 2025

Delta Lake Inn

Rome, NY

OTHER

Town Budget Process Technical Paper

It is that time of year again, and the town budget process in New York State can be confusing for both new town board members and seasoned officials.

[Click Here](#)

Also, Laird Petrie is available if you would like any help from him for budgeting.

Just let your circuit rider know.

**THE VILLAGE OF COPENHAGEN BOARD OF TRUSTEES
BOARD PACKET
OCTOBER 8, 2025**

TRAININGS

- **Upcoming OSC Webinars**

Training: The Office of the New York State Comptroller's (OSC) Local Government Academy is offering two online training opportunities in September.

Location: Webinar

Dates: Introduction to Governmental Accounting - September 3-4, 2025 & v Fiscal Stress Monitoring System Briefing for Local Governments - September 10, 2025

Website/Registration: September 3-4: [Click Here](#) & September 10: [Click Here](#)

- **Draft Intended Use Plans**

Training: The NYS Environmental Facilities Corporation and the Department of Health will host a webinar to review the Draft 2026 Intended Use Plans (IUPs) for the Clean Water and Drinking Water State Revolving Funds.

Location: Webinar

Dates: September 4, 2025 @ 1:00pm

Website/Registration: [Click Here](#)

- **NYAOT 2025 Planning & Zoning School**

Training: New York State Association of Towns Planning and Zoning School

Location: Fort William Henry Hotel & Conference Center in Lake George

Dates: September 13, 2025

Website/Registration: [Click Here](#)

- **NYCOM Fall Training School**

Training: Several concurrent sessions will be held on a variety of topics, including municipal finance, understanding vital records, local government 101 and 102, special events insurance, open meetings law, first amendment, and more.

Location: Lake Placid, NY

Dates: September 15 - 19, 2025

Website/Registration: [Click Here](#)

GRANTS

- **EFC Grant Applications Due**

The Water Infrastructure Improvement (WIIA) program provides competitive grants to help municipalities affordably undertake critical wastewater and drinking water infrastructure projects.

Due Date: September 12, 2025

Website: [Click Here](#)

- **Community Forest Grants**

NYS Department of Environmental Conservation (DEC) has announced \$1 million for grants available through the third round of the State's Community Forest Conservation Grant Program.

Due Date: September 17, 2025

Website: [Click Here](#)

- **\$53 Million in Grants Available for Swimming Facilities**

Governor Kathy Hochul announced the second round of the New York Statewide Investment in More Swimming (NY SWIMS) Initiative, offering \$53 million in capital grants to municipalities and nonprofits to expand safe swimming access across the state.

Due Date: September 24, 2025 - October 30, 2025

Website: [Click Here](#)

- **Community Development Block Grants**

The NYS Office of Homes and Community Renewal has several Community Development Block Grant (CDBG) grants currently open.

Due Date:

Website: [Click Here](#)

THE VILLAGE OF COPENHAGEN BOARD OF TRUSTEES
BOARD PACKET
OCTOBER 8, 2025

TRAININGS

- **Town Highways 96th Annual Conference**

Training: The NYS Association of Town Superintendents of Highways (NYSAOTSOH) will hold their 96th Annual Conference, Navigating the Rapids: Guiding Roads and Overcoming Obstacles.

Location: Niagara Falls, NY

Dates: September 23 - 26, 2025

Website/Registration: [Click Here](#)

- **Public Works Training School**

Training: Join the New York Conference of Mayors and the New York Water Environment Association as they present their Public Works Training School.

Location: Fort William Henry Hotel, 48 Canada Street, in Lake George

Dates: October 6-8, 2025

Website/Registration: [Click Here](#)

- **Cornell Local Roads Training**

Training: Cornell Local Roads Training

Location: Webinar

Dates: Various Dates

Website/Registration: [Click Here](#)

**THE VILLAGE OF COPENHAGEN BOARD OF TRUSTEES
BOARD PACKET
OCTOBER 8, 2025**

DPW

- MOWED ALL VILLAGE PROPERTIES 08/01/25
- WEED WACKED ALL VILLAGE PROPERTIES 08/01/25
- FILLED HANGING FLOWERPOTS AT HALL & BAND STAND 08/01/25
- PICKED UP TRASH THAT WAS AT PARK 08/01/25
- WATERED SPIDER PLANT ON RAMP IN FRONT OF VILLAGE HALL 08/01/25
- CALLED IN UFPO FOR POLE REPLACEMENT INFRONT OF BANDWAGON 08/04/25
- MOWED AND WEED WACKED WOODBATTLE WATER PLANT 08/04/25
- PICKED UP ORDER FOR THE VILLAGE REMODLE 08/04/25
- DID OFFICE INSPECTION ALL SET FOR THE MONTH 08/04/25
- MOWED PARK, BANDSTAND, BANDWAGON, HALL 08/06/25
- TOPPED OFF HANGING FLOWERPOT AT HALL 08/07/25
- SENT WATER REPORTS TO DOH 08/07/25
- TOOK WATER & SEWER SAMPLES TO CONVERSE LABS 08/07/25
- PICKED UP MOP SINK FOR VILLAGE HALL 08/07/25
- TOPPED HANGING BASKETS AT BANDSTAND 08/12/25
- BLEW OFF SIDEWALK IN FRONT OF BAND WAGON 08/07/25
- PICKED UP TRASH THAT WAS AT PARK, BANDSTAND & BANDWAGON 08/13/25
- MOWED AND WEDEATED STODDARD WATER PLANT 08/11/25
- WEED WACKED HYDRANT FROM WATER PLANT TO VILLAGE LINE 08/11/25
- WEED WACKED AROUND VILLAGE SIGNS 08/11/25
- FILLED RAIN BARREL DOWN AT BANDSTAND 08/12/25
- TWO LOADS OF RECYCLING 08/13/25
- STARTED WRITING DAILY SHEET ON WHAT WE DO AT WATER PLANT 08/13/25
- TOPPED OFF HANGING FLOWERS AT VILLAGE HALL 08/14/25
- PULLED THE TREE BY HOUSE THAT WAS DEAD 08/14/25
- TOOK DIRT & OLD TREE DOWN TO DENMARK 08/14/25
- HELPED MOVE STUFF IN OFFICE FOR REMODLE 08/14/25
- FILLED UP BIG FLOWERPOT AROUND VILLAGE THAT NEED TO BE FILLED 08/14/25
- TOUCHED UP AROUND HYDRANT BARRELS WITH RED PAINT 08/18/25
- CUT 32 EACH OF RED & SILVER REFLECTIVE TAPE FOR BARRELS 08/18/25
- MOWED INSIDE OF SEWER PLANT 08/15/25
- FIXED PLASTIC SUCTION LINE AT HIGH LIFT STATION 08/18/25
- TOPPED OFF HANGING FLOWERPOTS AT VILLAGE HALL 08/18/25
- TOPPED OFF HANGING FLOWERPOTS AT BANDSTAND SONE FILLING THEM UP AT 11:15AM
08/18/25
- PAINTED FIRE HYDRANT & SYMBOL ON BARRELS WITH BRIGHT YELLOW SPRAY PAINT
08/15/25
- TOOK OUT BULLET PROOF GLASS WINDOW AND COUNTERTOP IN CLERKS OFFICE 08/14/25
- CALLED IN TWO UFPO ONE FOR NEW POLE ON ROBERTS RD & ONE FOR SCHOOL BACK
PARKING LOT 08/20/25
- READ ALL VILLAGE AND DENMARKS METERS 08/20/25
- FIXED WATER LINE IN BATHROOM 08/20/25
- PUT NEW REFLECTIVE TAPE ON HYDRANT BARRELS 08/21/25
- PUT SONE ROAD GRINDING NEXT TO SIDEWALK NEXT TO FLEMMING SIDEWALK WHERE
IT SANK IN 08/21/25
- TOOK OLD SINK OUT OF BATHROOM 08/20/25
- PUT NEW SINK TOGETHER 08/21/25
- TOPPED OFF BOTH HANGING FLOWERS AT HALL & BANDSTAND 08/22/25
- MOWED HIGH SPOTS AT PARK, BANDSTAND, BANDWAGON, STEVES 08/22/25
- MOWED OUTSIDE OF SEWER PLANT AND WATERTOWER 08/21/22
- WEED WACKED, BANDSTAND, WATERTOWER, UNDER GUARD RAILS AT PARK AND
BANDWAGON 08/22/25
- TOPPED OFF FLOWERPOTS AT HALL 08/25/25

THE VILLAGE OF COPENHAGEN BOARD OF TRUSTEES

BOARD PACKET

OCTOBER 8, 2025

- TOPPED OFF FLOWERPOTS AT BANDSTAND 08/25/25
- PICKED UP MORE HYPO 08/25/25
- PUT NEW TED SIMMON'S SIGN UP DOWN AT PARK 08/25/25
- PULLED OUT GENERATOR AT SEWER PLANT AND MOVED STUFF AROUND FOR NEW FURNACE INSTALLATION 08/25/25
- TURNED OFF BLOWER #1 AND TURNED ON BLOWER #2 08/25/25
- CHANGED OIL IN BLOWER #1 AND CHECKED BELTS ALSO ALL GOOD 3000 HR. 08/25/25
- PUT SOME SMELLY STUFF DOWN DRAINS AT SEWER PLANT 08/25/25
- REORGANIZED CABINET IN DPW OFFICE, THREW OUT WHAT WAS NO GOOD 08/25/25

*New Furnace
S.T.P.
September 2025*



*New Furnace
S.T.P.
September 2025*



THE VILLAGE OF COPENHAGEN BOARD OF TRUSTEES
BOARD PACKET
OCTOBER 8, 2025

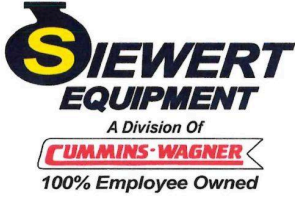

Headquarters: 175 Akron Street, Rochester, NY 14609

Service Department:

Buffalo | Rochester | Albany
Ph: (585) 224-7929
F (585) 224-7968
www.siewertequipment.com

*Serving New York Municipalities
and Industry since 1949.*

Laser Alignment Specialists

EMAIL / FAX TRANSMITTAL FORM

Date: Tuesday, September 2, 2025
To: Village of Copenhagen
Attention: Dave Potocki
Fax/Email: djpw@villageofcopenhagen.com **Phone:** 315-775-4820
From: Sunny Kopano
Title: Service Coordinator

COMMENTS

Subject/Job: Roch60849
Make/Model: Gorman Rupp
Serial Number: Mill Street pump station
PO / Ref. No:

Please find attached our service proposal and let us know if you have any questions. Should you choose to proceed, kindly sign the proposal and return with purchase order or credit card number as approval for us to schedule and proceed.

Thank you for choosing Siewert Equipment.

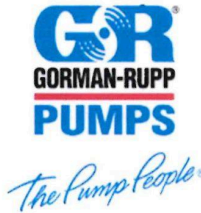

Copy: Nick Brown

Total Number of Pages Including Cover:

9/2/2025 3:14 PM

**THE VILLAGE OF COPENHAGEN BOARD OF TRUSTEES
BOARD PACKET
OCTOBER 8, 2025**

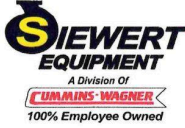

Service Department
Buffalo | Rochester | Albany

Voice: Ph: (585) 224-7929
Fax: F (585) 224-7968

Date: September 2, 2025
Make/Model: Gorman Rupp

Serial #: Mill Street pump station
Proposal #: 092504
PO #:

To: Village of Copenhagen
9915 State Route 12
Copenhagen NY 13626
Attn: Dave Potocki
Job: Roch60849

Work/Solution Proposed

Siewert Equipment to send 1 technician onsite to remove a bad section of pipe in the Mill Street Gorman Rupp pump station with a suction leak below the 90 degree elbow at the flange. Service mechanic will cut the down spout pipe and install a new coupling, 90 degree elbow, flange, and new section of pipe.

- Repair the aforementioned unit utilizing the attached parts list and in accordance with OEM tolerances & specifications. Genuine OEM replacement parts will be provided unless specifically noted otherwise.
- 2.) Customer is responsible for establishing a safe, clean and accessible work environment.
- 3.) Siewert Equipment is fully authorized for Service & Repair by Grundfos Pump Company.
- 4.) If Siewert Equipment Company determines that additional parts/labor are required that were not included in this initial quote, you will be notified for review and approval before we proceed.
- 5.) Public Works proposals are in accordance with Article 8, Section 220 of the New York State Labor Law.
- 6.) Payment terms are Net 30 days. A 3% processing surcharge applies to all credit card orders. Price quoted does not apply to credit card payments. Please request a revised quote if you need the option to pay by credit card. Merchant name on credit card statement will be **Cummins-Wagner**. This proposal is valid for the next 30 Days and subject to attached terms and conditions.

Exclusions

1.) Any work not specifically described above.

PRICE FOR THIS WORK: \$3,693 1-2 Weeks
~ Repair lead time:

Repairs include 90-day warranty for defective parts & workmanship. New unit includes (1) year manufacturer's warranty.

**** PLEASE INDICATE ACTION(S) REQUIRED BY CHECKING ASSOCIATED BOXES AND SIGNING BELOW ****

Proceed with Work

This proposal is hereby accepted and Siewert Equipment is authorized to proceed with the work; subject, to credit approval.

Tax Exempt: Yes * No * If yes, fax/email a copy of tax exempt certificate.

NYS publicly funded work requiring specific wage rates & certified payroll? Yes No

If yes, provide written requirements in advance. Where applicable, quoted price of work will be adjusted accordingly.

Purchase Order Number:

Credit Card: (✓ one) MasterCard Visa American Express

Card # Expiration Security Code

Credit Card: A 3% processing surcharge applies to all credit card orders. Merchant name on statement is Cummins-Wagner.

Dave Potocki
Village of Copenhagen

Siewert Equipment Co. Inc.

Signature: _____

Sunny Kopano
Signature: _____

Name: _____

Name: **Sunny Kopano**

Title: _____

Title: Service Coordinator

Date: _____

Date: 9/2/2025

**THE VILLAGE OF COPENHAGEN BOARD OF TRUSTEES
BOARD PACKET
OCTOBER 8, 2025**

Roch 2025 - Copenhagen, VO - Gorman Rupp - Mill St Station service proposal 2



Service Department
Buffalo | Rochester | Albany

Voice: Ph: (585) 224-7929
Fax: F (585) 224-7968

Date: **September 2, 2025**
Make/Model: Gorman Rupp

Serial #: Mill Street pump station
Proposal #: 092504
PO #: 0

To: Village of Copenhagen
9915 State Route 12
Copenhagen NY 13626
Attn: Dave Potocki
Job:

Material List	
Quantity	Description
1	90 Degree 4" PVC sch 80
1	Flange 4" PVC sch 80
1	Coupling 4" PVC sch 80
1	6" Pipe PVC sch 80
2	4" Riser Clamp
2	4" Flange Gasket
1	PVC Glue and Primer
8	5/8" Bolts x 4"
8	5/8" Nuts

THE VILLAGE OF COPENHAGEN BOARD OF TRUSTEES
BOARD PACKET
OCTOBER 8, 2025

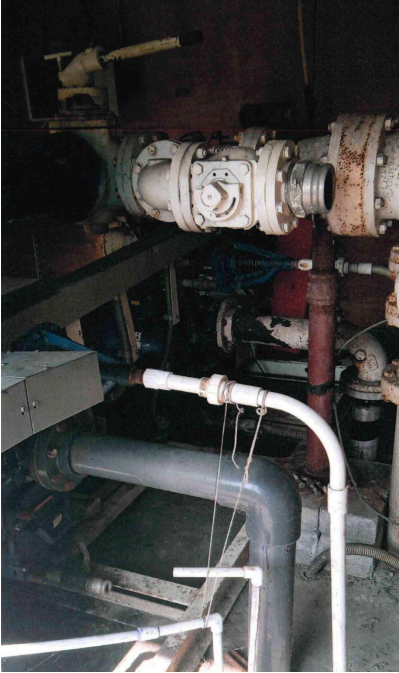

COLIN FAYLE PAYMENT

THE VILLAGE OF COPENHAGEN BOARD OF TRUSTEES
BOARD PACKET
OCTOBER 8, 2025

DPW REPORT FOR OCTOBER 2018

- Painted metal box for back of Small Kubota tractor for winter
- put new slow moving sign on back of metal box and put new reflector on side of box
- mowed grass at bandstand and over next to Steve's house and weed wacked too and next to village hall and down next to restaurant
- Going up Monday to see how much it is going to cost to get a piece of sheet metal welded on both sides of the garbage truck
- took garbage truck over to fire hall
- Had small meeting with Matt Cooper about moving radio tower from old water tower to new one
- Had two guys come from Lowville to work on lagoons at sewer plant defusers
- Changed stage one filters with prewashed filters
- Shut off water at Chubay's house on Grove Street
- did final reading at bates house on Grove street they are moving
- Changed stage one filters with new ones
- Had to get another chlorine pump we didn't have one that worked got a spare one from P&T for now P&T is going to get us a new one for the water plant
- Siewert came out and looked at the High Lift station to see why one of the pumps wouldn't keep a prime
- put doors back on little Kubota
- Put flag at half staff
- brought down plow that goes on pickup truck and put it in other shop
- washed two sets of stage one filters
- changed out stage one filters with prewashed filters
- got more chlorine for water plant
- Wells have bounced back well #3- 85.1ft, well #4- 108.6ft, well #5- 89.1ft
- was running wells 4, 5 just turned off well #4 and only running well 5
- picked up remaining pieces of black top left on side of road from paving job

**THE VILLAGE OF COPENHAGEN BOARD OF TRUSTEES
BOARD PACKET
OCTOBER 8, 2025**

OCTOBER 2018 ABSTRACT OF AUDITED VOUCHERS

No. 5

SEWER FUND

VILLAGE OF COPENHAGEN, COUNTY OF LEWIS, NEW YORK
DATE OF AUDIT: OCTOBER 31, 2018

VOUCHER #	NAME OF CLAIMANT	v	APPROPRIATION CODE	AMOUNT	CHECK #
46	SUE PARKER - Mileage		G8110.4	43.87	1439
47	NATIONALGRID		G8130.4	906.48	1440
48	VERIZON		G8130.4	10.78	1433
49	CONVERSE		G8130.4	60.00	1434
50	WINDSTREAM		G8130.4	72.87	1435
51	BCA		G8130.41	850.00	1436
52	THOMAS WIDRICK		G8350.41	250.00	1437
53	COLIN FAYLE		G8350.41	300.00	1438
	void 1431 1432				
				2,494.00	

SUMMARY

G8110.4	43.87
G8130.4	1,050.13
G8130.41	850.00
G8350.41	550.00
	<u>2,494.00</u>

TRUSTEE Darin R Vogt
 TRUSTEE Benjamin...
 TRUSTEE David...
 TRUSTEE M...

To the Treasurer of the VILLAGE OF COPENHAGEN:

The above listed claims having been presented to the Village Board of the Village of Copenhagen, and having been duly audited and allowed in the amounts as shown on the above mentioned date, you are hereby authorized and directed to pay each of the listed claimants the amount allowed upon his claim appearing opposite his name.

In Witness Whereof, I have hereunto set my hand as Mayor Scott L. Alexander of the Village of Copenhagen this ___ day of _____, 20__.

Clerk _____

THE VILLAGE OF COPENHAGEN BOARD OF TRUSTEES
BOARD PACKET
OCTOBER 8, 2025

50

VILLAGE OF COPENHAGEN

Bill of

Thomas Widrick

No. _____

Nature G8350.41

Amount Claimed \$ 250.00

Amount Allowed \$ 250.00

Filed this 31st day of

October 2018

Shyella Parker
Village Clerk

WILLIAMSON LAW BOOK CO., VICTOR, NY 14564

Date _____ 20 _____

Signature of Claimant

claim; that the items of said claim are, in all respects, correct; that the disbursements and services therein charged have been in fact made and rendered, and that no part thereof has been paid or satisfied, and that the same is justly due and owing.

hereby certifies that he is the person making the within

STATE OF NEW YORK
LEWIS COUNTY
VILLAGE OF COPENHAGEN }
SS.

**THE VILLAGE OF COPENHAGEN BOARD OF TRUSTEES
BOARD PACKET
OCTOBER 8, 2025**

Thomas Widrick
5611 Trinity Ave ext. Lowville, NY 13367

INVOICE

1

Bill To:
Village of Copenhagen
PO Box 237 Copenhagen, NY 13626

Date: Oct 2, 2018
Balance Due: \$250.00

Item	Quantity	Rate	Amount
Lagoon Work	1	\$250.00	\$250.00

Subtotal: \$250.00
Total: \$250.00

THE VILLAGE OF COPENHAGEN BOARD OF TRUSTEES
BOARD PACKET
OCTOBER 8, 2025

3

VILLAGE OF COPENHAGEN

Bill of

Colin Fayle

No. _____

Nature G835041

Amount Claimed \$ 300.00

Amount Allowed \$ 300.00

Filed this 31st day of

October 2018

Shyette Parks
Village Clerk

WILLIAMSON LAW BOOK CO. VICTOR, NY 14564

Date _____ 20 _____

Signature of Claimant

hereby certifies that he is the person making the within claim; that the items of said claim are, in all respects, correct; that the disbursements and services therein charged have been in fact made and rendered, and that no part thereof has been paid or satisfied, and that the same is justly due and owing.

STATE OF NEW YORK
LEWIS COUNTY
VILLAGE OF COPENHAGEN } SS.

THE VILLAGE OF COPENHAGEN BOARD OF TRUSTEES
BOARD PACKET
OCTOBER 8, 2025

Colin Fayle
5265 Dayan st. Lowville, NY 13367

INVOICE
2

Bill To:
Village of Copenhagen
PO Box 237 Copenhagen, NY 13626

Date: Oct 2, 2018
Balance Due: \$ 300.00

Item	Quantity	Rate	Amount
Lagoon Work	1	\$ 300.00	\$ 300.00
		Subtotal:	\$ 300.00
		Total:	\$ 300.00

**THE VILLAGE OF COPENHAGEN BOARD OF TRUSTEES
BOARD PACKET
OCTOBER 8, 2025**

**Village of Copenhagen
Local Law No. ____ of the year 2025
Repeal and Replace
Section 18 of Local Law No. 4 of 2010
Property Maintenance**

The intent of the proposed action is to repeal "Section 18: Emergency Actions" which exists in the Village of Copenhagen Property Maintenance Law (Local Law No. 4 of 2010) and replace the same with a new "Section 18: Emergency Actions" within the Property Maintenance Law of the Village of Copenhagen.

Once the existing Section 18 is repealed, it shall be replaced with the following:

Section 18: Emergency Actions

Where it reasonably appears that there is a present danger to the life, safety, or health of any person or property and such danger is attributable to unsanitary conditions related to garbage, litter, refuse, rubbish, and/or debris, and that such danger will exist until the offending garbage, litter, refuse, rubbish, and/or debris is removed, the Village Board may by resolution authorize the immediate removal of the same. Written notice of the same shall be provided to persons having interests in the property within a reasonable time and such notice shall be posted at the property.

The actual cost of correcting such condition [minimum charge of one (1) hour labor and one (1) hour equipment, plus materials], plus five percent (5%) thereof for inspection and other costs in connection therewith, shall be calculated and certified by the Village Clerk and shall thereafter become and be a lien upon the property whereon such condition exists and/or is located and shall be added to and become a part of the taxes next to be assessed and levied upon such lot or land and shall bear interest at the same rate as taxes and shall be collected and enforced by the same officer and in the same manner as taxes.

THE VILLAGE OF COPENHAGEN BOARD OF TRUSTEES
BOARD PACKET
OCTOBER 8, 2025

Village of Copenhagen

9915 State Rt 12
PO Box 237
Copenhagen, NY 13626
Tel: 315-688-4229

RESOLUTION ___ of 2025

**ENACT LOCAL LAW NO. ___ of 2025
REPEAL AND REPLACE SECTION 18 OF LOCAL LAW NO. 4 OF 2010
PROPERTY MAINTENANCE**

WHEREAS, the Village Board for the Village of Copenhagen, New York is interested in enacting a Local Law repealing and replacing Section 18 of the Village Property Maintenance Law; and

WHEREAS, the Village Board has determined to proceed with legislation regarding Property Maintenance; and

WHEREAS, the Village Board has reviewed the proposed legislation and has further determined that enacting the same would be in the best interests of the Village.

NOW, THEREFORE, BE IT RESOLVED, by the Village Board of the Village of Copenhagen, New York as follows:

1. The forgoing recitation is incorporated herein and made a part hereof as if set forth hereafter.
2. The Village Board hereby enacts the Local Law repealing and replacing Section 18 of the Village Property Maintenance Law as being in the best interests of the Village of Copenhagen.
3. The Mayor for the Village of Copenhagen and the Village Clerk for the Village of Copenhagen, their respective agents and employees are authorized to sign all documents and take all steps necessary to enact this legislation.

Page 1 of 2

FIRE DEPARTMENT
RUTLAND

COPENHAGEN FIRE DEPARTMENT INC

**PUBLIC COMMENTS/INFORMATIONAL
SPDES PERMIT**

**THE VILLAGE OF COPENHAGEN BOARD OF TRUSTEES
BOARD PACKET
OCTOBER 8, 2025**

New York State Department of Environmental Conservation
Division of Environmental Permits
NYSDEC HEADQUARTERS
625 BROADWAY
ALBANY, NY 12233
(518) 402-9167

RECEIVED

AUG 28 2025



Village of Copenhagen

SPDES PERMIT RENEWAL

7/18/2025

VILLAGE OF COPENHAGEN
PO BOX 237
COPENHAGEN NY 13626

Permittee Name: VILLAGE OF COPENHAGEN
Facility Name: Copenhagen Consolidated Water Supply
Ind. Code: 4941 County: LEWIS
DEC ID: 6-2322-00010/00003 SPDES No.: NY0257991
Permit Effective Date: 9/1/2025
Permit Expiration Date: 8/31/2030

Dear Permittee,

The State Pollutant Discharge Elimination System (SPDES) permit renewal for the facility referenced above is approved with the new effective and expiration dates. This letter together with the previous valid permit for this facility effective on 09/18/2020 and any subsequent modifications constitute authorization to discharge wastewater in accordance with all terms, conditions and limitations specified in the previously issued permit(s).

As a reminder, SPDES permits are renewed at a central location in Albany in order to make the process more efficient. All other concerns with your permit, including applications for permit modification or transfer to a new owner, a name change, and other questions, should be directed to:

Regional Permit Administrator
NYSDEC Region 6 Headquarters
State Office Building - 317 Washington St
Watertown, NY 13601
(315) 785-2246

If you have already filed an application for modification of your permit, it will be processed separately by that office.

If you have questions concerning this permit renewal, please contact KATHERINE M MURRAY at (518) 402-8413.

Sincerely,

James J. Eldred
Environmental Analyst

NYDOL VISIT

**THE VILLAGE OF COPENHAGEN BOARD OF TRUSTEES
BOARD PACKET
OCTOBER 8, 2025**

**New York State Department of Labor
Public Employee Safety and Health Bureau**

Inspection Number: 1845032
Inspection Date: 08/19/2025-08/19/2025
Issuance Date: 08/27/2025
CSHO ID P5199



Notice of Violation and Order to Comply

Establishment: Village of Copenhagen Village Hall
Inspection Site: 9915 State Rt 12 Copenhagen, NY 13626

Citation 1 Item 1 Type of Violation: **Non Serious**

12 NYCRR Part 801.29(a): The employer did not use the SH 900 Log of Work-Related Injuries and Illnesses, SH 900.1 Annual Summary of Work-Related Injuries and Illnesses and SH 900.2 Injury and Illness Incident report, or equivalent forms, for recordable injuries and illnesses:

a. Village of Copenhagen Village Hall, on or about 8/19/2025, the employer did not maintain required SH-900 or equivalent injury and illness documentation for each establishment operated by the Village.

Date by Which Violation Must Be Abated:

October 15, 2025

**THE VILLAGE OF COPENHAGEN BOARD OF TRUSTEES
BOARD PACKET
OCTOBER 8, 2025**

New York State Department of Labor
Public Employee Safety and Health Bureau

Inspection Number: 1845032
Inspection Date: 08/19/2025-08/19/2025
Issuance Date: 08/27/2025
CSHO ID P5199



Notice of Violation and Order to Comply

Establishment: Village of Copenhagen Village Hall
Inspection Site: 9915 State Rt 12 Copenhagen, NY 13626

Citation 1 Item 2 Type of Violation: **Non Serious**

12 NYCRR Part 801.47(a): Employer did not post poster providing information relating to the job safety and health protection afforded to public employees by the provisions of Labor Law, section 27-a.

a. Village of Copenhagen Village Hall, on or about 8/19/2025, employer did not have NYS PESH poster posted.

Date by Which Violation Must Be Abated:

Corrected During Inspection

Luke Parga

Luke Parga
Supervising Safety and Health Inspector

See pages 1 through 2 of this Notice of Violation and Order to Comply for information on employer and employee rights and responsibilities.

**THE VILLAGE OF COPENHAGEN BOARD OF TRUSTEES
BOARD PACKET
OCTOBER 8, 2025**

CLERK AUGUSTINE STILL NEEDS TO RETROACTIVELY MAKE INJURY AND ILLNESS REPORTS FROM THE TIME OF APPOINTMENT TO CURRENT. PESH HAS NOTHING FROM VILLAGE OF COPENHAGEN SINCE THEIR LAST VISIT IN 2008.

SHARI SIMMONS LETTER

Sept 5 2025

Copenhagen Board,

I would at this time express my disappointment in the care of the pavilion lawn. Many people in our community have used this pavilion and it is a great asset to our community. So why does it receive minimal care from the village crew.?

I have asked Kim Vogt two times about getting it weed eaten and I have also talked to Scott Alexander who in turn contact Mark Souva. I had expected that it was taken care but it is now at least three weeks since I last talked to Scott Alexander about it. I have had people go and weed eat it earlier in the season as well in past year. I have even offered to meet the village lawn mower to show him . it has a stone border on the garden so pretty easy I think. This village crew mows and maintains as well as weed eat several places in the village even property that the village does not own but a beautiful park we now have is given second rate care. They weed eat the bandstand area but for some reason can't do the park. I believe they have no excuse other than lack of want. I have volunteered to help by showing them where it needs trimming and no one has ever reached out to any of my family asking for some guidance it is just ignored and allowed to grow up in to a mess. Then I end up paying someone to go up and do it because I can't stand seeing it being neglected.

I also asked one of the village guys about why the picnic tables have never had stain or preservative on them to protect so they last a long time. I even offered the same stain the pavilion has to them. Once again someone worked hard and donated these to have no maintenance and actually left under eaves last winter and the snow coming off roof buried them. My answer was "no one has ever told us to do it". Seriously anyone knows that to preserve outdoor items they need a little maintenance.

I know the village board members have made the effort to get the park trimmed up but apparently it has fallen on deaf ears.

I am hoping by writing this letter that it will give your village employees a little fire to get motivated to make this park as beautiful as it should be so many people will be able to enjoy it for many many years.

Sincerely ,

Shari Simmons

LETTER FROM HOLLIE POWIS

Good morning,

Mill street is in terrible disrepair. It has water running over the roadway frequently. As a taxpayer I would like to know when this road will be getting repairs done to it.

Thank you

**THE VILLAGE OF COPENHAGEN BOARD OF TRUSTEES
BOARD PACKET
OCTOBER 8, 2025**

--

Hollie Powis
Powis Contracting, Inc

OLD BUSINESS

SEWER USE LAW-LAWYERS

WINDSTREAM

ANCA

SHARED SERVICES WITH CASTORLAND:

IMA WATER & SEWER

GARBAGE TRUCK

LEWIS COUNTY DRAINAGE

MAGNIFLOOD VISIT AND NEW QUOTE

**THE VILLAGE OF COPENHAGEN BOARD OF TRUSTEES
BOARD PACKET
OCTOBER 8, 2025**

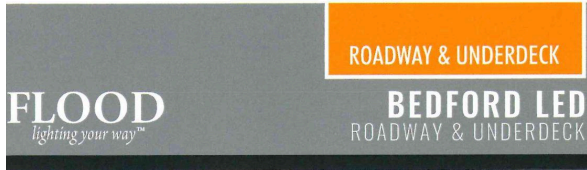

The Bedford LED is a vintage styled pedestrian/roadway luminaire that was designed with roadway safety and energy efficiency in mind-providing for evenly distributed lighting with maximum lumen output and minimal glare. Glare reduction and uniformity of light distribution are two factors in reducing high speed roadway accidents.

CONSTRUCTION:

The BEDFORD LED comes welded to its own decorative mounting arm, for wall or pole mounting. The diffused refractor and cast aluminum fitter are reminiscent of fixtures that were popular at the turn of the twentieth century. The cast aluminum housing holds the ballast assembly. All hardware is corrosion-resistant or stainless steel.

MOUNTING:

The slipfitter is designed to slip 3" O.D. pole bracket and secures with (3) corrosion-resistant and tamper-resistant set screws.

LED LIGHT ENGINE:

Mag-LED light engine with built-in lens photometry in an IP-66 rated system. The fixture meets UL-1598 standards for wet locations. The driver operates from 120-277 volts with an optional 0-10 volt dimming interface.

LENS:

The optically clear LED lens is offered in both Type III and Type V distributions. A clear acrylic lens is standard.

FINISH:

Standard finish is TGIC acrylic powder coat in MagniBronze. Other colors available from factory on request.

FLOOD
lighting your way™

BEDFORD LED
ROADWAY & UNDERDECK

ORDERING INFORMATION:			
CAT. NO.	DESCRIPTION	WEIGHT	EPA <small>Estimated Projected Watt</small>
BE-LED-49	49W White LED 120-277V @6300 Lumens	10.0lbs	0.90
BE-LED-98	98W White LED 120-277V @12600 Lumens	10.0lbs	0.90



OPTIONAL FEATURES:

- PM: Pole Mounting
- WM: Wall Mounting

COLOR CHART OPTIONS:

- GBLK: Gloss Black
- MBLK: Matte Black
- DB: Dark Bronze
- CBLK: Crinkle Black
- WH: White
- LG: Light Gray
- BGRN: Black Green
- DGRN: Dot Green
- CC: Custom Color

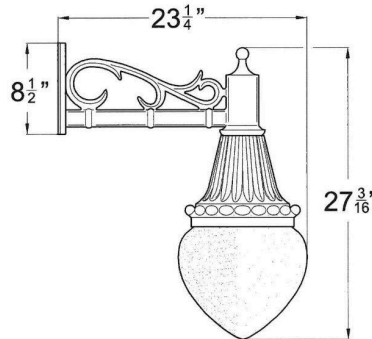

THE VILLAGE OF COPENHAGEN BOARD OF TRUSTEES
BOARD PACKET
OCTOBER 8, 2025

MAGNIFLOOD INC.

Sept. 8, 2025

Village of Copenhagen NY
Attn: Kimberly Augustine

RE: Material Quote

Dear Kimberly,

Thank you for the inquiry. The pricing that you requested from Walter is as follows:

BED-LED-49-CC-PC-MBLK [Bedford luminaire with color changing LED module] and
WB3-10-MBLK mounting bracket **\$1355/assembly**

Plus freight, via common carrier. (NOTE: we will be able to get you a freight estimate once we know the quantity you are planning to order).

Please review and contact our office with any questions.

Respectfully,

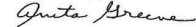

Anita Greene, MagniFlood Inc.
MagniFlood Inc.
7200 New Horizons Blvd.
Amityville NY 11701
631-226-1000
anita@magniflood.com

1 |

7200 New Horizons Blvd - North Amityville, NY 11701
Tel:631.226.1000 Fax:631.226.4444 www.magniflood.com

NATURAL BRIDGE
BRADSTREET CURB STOP
CATARACT ST HYDRANT
WOODBATTLE WATER PLANT- WATERMAN DEBRIS
FUEL TANKS AT VILLAGE HALL
WEED EATING VILLAGE PROPERTY: VILLAGE HALL. BANDSTAND, PAVILLION ETC...

NEW BUSINESS
BIDS FOR SNOW AND OTHER EQUIPMENT
MAGNIFLOOD RETROFITTED STOP SIGN LIGHTS



SOLAR • FLASHING • LED

RETROFIT

STOP SIGNS

INCLUDED IN KIT:

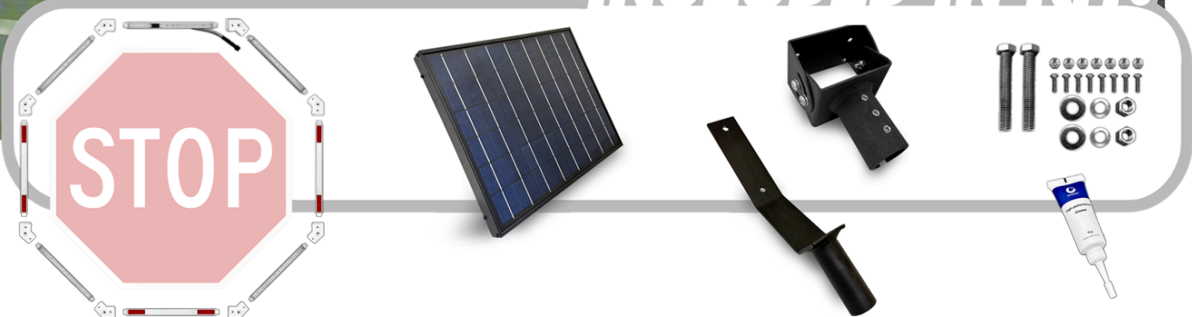

DENMARK WATER CONNECTION FOR: ETHEL PETRUS

**THE VILLAGE OF COPENHAGEN BOARD OF TRUSTEES
BOARD PACKET
OCTOBER 8, 2025**

Town of Denmark Town Clerk / Tax Collector / Registrar's Office

Prudence Lyn Greene

3707 Roberts Road

Carthage, NY 13619

Phone 315-493-3846 ext 1 Fax 315-493-4809

Email: townclerk@townofdenmarkny.gov

Village of Copenhagen
PO Box 237
Copenhagen, NY 13626

August 25, 2025

Re: Ethel Petrus request for water connection

Dear Village of Copenhagen Mayor and Trustees,

We have received a request from Ethel Petrus to connect to the water system. Her address is 9807 River Road, Copenhagen, NY 13626 and her tax map number is 140.00-03-07.000.

Can you please consider this request at your next meeting and notify the Town of Denmark of your decision?

Sincerely,



Prudence L. Greene

Town of Denmark Town Clerk

OPEN FORUM

FINANCIALS

BUDGET CODE TRANSFER

TREASURER REPORT

**THE VILLAGE OF COPENHAGEN BOARD OF TRUSTEES
BOARD PACKET
OCTOBER 8, 2025**

MONTHLY REPORT OF TREASURER

TO THE VILLAGE BOARD OF THE VILLAGE OF COPENHAGEN:

The following is a detailed statement of all moneys received AND disbursed BY me during the month of August, 2025:

DATED: September 8, 2025

TREASURER

	Balance 07/31/2025	Increases	Decreases	Balance 08/31/2025
A GENERAL FUND - TOWNWIDE				
CASH - CHECKING	210,840.02	59,337.63	38,014.31	232,163.34
CASH - SAVINGS	417,496.48	354.09	0.00	417,850.57
PETTY CASH	200.00	0.00	0.00	200.00
TOTAL	628,536.50	59,691.72	38,014.31	650,213.91
F WATER FUND				
CASH - CHECKING	193,837.83	9,614.31	40,510.98	162,941.16
CASH - SAVINGS	123,187.27	2.10	0.00	123,189.37
TOTAL	317,025.10	9,616.41	40,510.98	286,130.53
G SEWER FUND				
CASH - CHECKING	211,565.70	7,223.56	21,377.92	197,411.34
CASH - SAVINGS	116,218.62	1.97	0.00	116,220.59
TOTAL	327,784.32	7,225.53	21,377.92	313,631.93
H CAPITAL FUND				
	0.00	0.00	0.00	0.00
TOTAL	0.00	0.00	0.00	0.00
SF FIRE DISTRICT				
	0.00	0.00	0.00	0.00
TOTAL	0.00	0.00	0.00	0.00
TA TRUST & AGENCY				
CASH - CHECKING	191.46	13,695.53	13,886.88	0.11
TOTAL	191.46	13,695.53	13,886.88	0.11
TOTAL ALL FUNDS	1,273,537.38	90,229.19	113,790.09	1,249,976.48

PAY BILLS

ADJOURNMENT

NEXT MEETING OCTOBER 8TH

**THE VILLAGE OF COPENHAGEN BOARD OF TRUSTEES
BOARD PACKET
OCTOBER 8, 2025**

SEE YOU THEN!